



TELESCOPIC HANDLERS

TX130-33/TX130-40/TX130-45
TX140-45 - TX170-45



Mast heights
Lift capacities
Power of engines

13 m/14 m/17 m
3 to 4.5 t
99 hp to 118 hp



SECURE BASE

Case TX telescopic handlers offer impressive stability through a combination of a long wheelbase, low boom pivot point and optimised counterweight. **Total stability. Maximum lift capacity.**

POWER TO WORK

The TX telehandler range is powered by high output Case engines, offering 99 hp on TX130-33 model and now 118 hp from a new climate friendly Tier III low emissions engine in the TX130-40 and above. This engine combines low fuel consumption with a strong 516 Nm of torque, enough to pull the machine through the toughest of site conditions. All engines are mounted longitudinally on the side of the machine, for a maximum transfer of power and ease of service.

High output. Low emissions and consumption.

REACHING HIGH

Robust boom construction with powerful hydraulic cylinders, or chain extension on some 13 m models, offers excellent range of working heights up to 17 m. Hydraulic frame levelling, along with audible and visual safe load indication ensures secure placing of loads at any height or reach.

Design integrity. Maximum capacity.



ALL ROUND EXCELLENCE

With a curved front screen and maximum glazed area in side and rear windows, the TX cab offers superb visibility all round the machine. A low engine canopy to the right of the machine and a low mounted control panel to the front, ensure that the operator always has a clean line of sight for efficiency and safety. Reduced height mast pivot points ensure that the operator has good visibility even to the rear of the telescopic handler. Both the cab door and the left hand window can be opened independently, locking back against the cab structure for security.

Unparalleled visibility. Safe operation.

ALL TERRAIN CAPABILITY

Powershift transmissions handle high power delivery without heat build-up. Smooth gear shifting and three steering modes ensure that the operator can work in the toughest site conditions. Four wheel steering greatly reduces turning circle, while crab steer offers the perfect solution when working against obstacles.

Outstanding manoeuvrability. Reliable components.

TOTAL CONTROL

With standard pilot controls for all hydraulic functions the Case TX telehandler is an easy machine to drive. Load sensing, flow sharing hydraulics, in combination with a smooth Powershift transmission, ensure independent movement of all hydraulic functions, with precision and accuracy. Low effort control levers reduce operator fatigue, ensuring high productivity and maximum safety throughout the working day.

Smooth operation. Precision control.

MAINTENANCE ACCESS

Side-mounted engine with full length lift-up canopy ensures access for ground level servicing and regular maintenance. All filters and fill points easily accessible, for minimum downtime and maximum productivity. Main hydraulic valve mounted at the rear of the machine, can be reached through separate panel without having to move other components.

Design integrity. Minimum downtime.

ATTACHMENT CARRIER

Case dealers offer a wide range of options, tyres and attachments to perfectly customise the machine to your individual requirements. Mechanical or hydraulic carriers can be specified along with optional sideshift capability. Customers can choose a carrier compatible with Case attachments or one designed to fit their existing buckets and work tools. Attachments include pallet forks, 4-in-1 buckets, crane booms, road sweepers, cement mixers and a range of personnel platforms, with or without radio control.

Multiple use. Versatility built-in.



TWO TELESCOPIC DESIGNS



The TX range uses robust telescopic booms with inherent rigidity and strength to allow many hours of safe lifting. The TX130-33 has a chain driven extension for the second boom section, while all larger machines use an internally mounted hydraulic twin cylinder to extend the boom. All models are equipped with safety valves on the lift, tilt and stabiliser cylinders, to prevent the boom dropping in the case of hose failure.

Visual and audible warning devices signaling overload are incorporated in the upper right corner of all cabs. On TX130-40 and above models, a strict safety device automatically prevents any hazardous extension of the mast. This feature makes the TX130-40 and above models suitable for the use of man platforms. Case provides a complete range of man baskets, fixed, orientable or even remotely radio controlled for tasks requiring to carry personnel.

HIGH LOAD CAPACITIES



There is a Case TX telehandler for every task on the construction site. Customers can choose from 13 m, 14 m and 17 m working heights, with lifting capacities from 3.3 to 4.5 tons. The smallest machines can be used without the need for stabilisers and there are several models with narrow stabilisers that open within the machine width. Wide stabiliser legs (standard on 17 meter model) are provided for maximum stability while lifting on the heavier models, giving Case some of the highest lifting capacities in the market.

HIGH MANOEUVRABILITY DRIVELINE



TX machines are incredibly agile, moving rapidly about the site thanks to a four-speed Powershift transmission and the easy to use three mode steering system. This combination of proven components ensures that there is no costly heat build-up in the transmission, even when travelling at high speeds on the road, where permitted.

The use of flow sharing hydraulics, along with the Powershift transmission, ensures precision work can be accomplished with ease. The single servo lever that controls all hydraulic functions also has a transmission cut-out button, giving the operator total control of the machine without having to move a hand away from the servo or the steering wheel. This ensures maximum safe use on site and reduced operator effort, cutting operator fatigue and boosting productivity.

OPERATOR'S CAB

From its initial conception the Case telehandler cab has led the field in terms of ergonomics, visibility and safety. Its curved top with wrap around glazing offers unparalleled visibility of the boom and the load. A glazed door, with opening window, provides easy access to the cab and the deep glass, low engine canopy and low boom pivot point ensure an excellent view all around the machine. This is a major contributing factor to increased site safety and prevents damage to the machine when manoeuvring in confined spaces. All instruments are placed in a low level console to further boost visibility to the front of the machine. Simple, single lever servo controls are easy to use and the operator has plenty of space in the ROPS/FOPS cab to remain comfortable throughout the day.



ENGINE



The TX telescopic handler range is powered by a 4.5 litre Case turbo engine. All machines are equipped with a low emission Tier III climate friendly engine, that with turbocharging and aftercooling offers from 99 hp to a healthy 118 hp and a powerful 516 Nm of torque.

Mounted on the side of the machine, the engine is easily accessible for all regular service and maintenance work, with filters and fill points all reached from ground level. Long service intervals and compatibility with the Case electronic service tool (EST) ensure minimum downtime, increasing profitability and keeping your machines at work.

FLOW SHARING HYDRAULICS



A fully load sensing hydraulic system, with flow sharing technology, allows independent use of all hydraulic functions. All major operations, such as lift and lower and forward reach, are controlled from a single servo lever, allowing the operator to keep one hand on the steering wheel when manoeuvring to a loading position. The flow sharing system ensures smooth lifting and reach and provides power when working with varied attachments. The main hydraulic valve is mounted at the rear of the machine and is fully accessible through a separate cover, without having to remove additional components, cutting diagnostic and maintenance time and boosting profitability.

POWERSHIFT 3 STEERING MODES



A proven Powershift transmission delivers four forward and three reverse speeds, with no heat build up despite high manoeuvring speeds. Working in combination with the flow sharing hydraulic system, the Powershift transmission offers precise control with high tractability, ideal for use on hard standing or in tough construction project conditions.

Three mode steering, offering two wheel, four wheel and crab modes, ensures even the largest model in the range has compact and agile manoeuvring dimensions. Four wheel steering provides the smallest possible turning radius, while crab steer offers the perfect solution when working alongside structures or for backfilling when working with a bucket.







SPECIFICATIONS

TX 130-33

with narrow stabilisers

ENGINE

Make _____ CNH U.K. Limited (for Case)
 EPA ** family _____ 8NHXL04.5DAB
 Model _____ 445TA/MNK
 Engine type _____ F4GE9484F* J600
 Net Power _____ 99 hp/74kW @2200 rpm
 (According to 80/1269 CEE)
 Max Torque _____ 430 Nm@1250 rpm
 Turbo aftercooled, Tier 3, 4 cylinder, 2 valves per cylinder

TRANSMISSION

Type _____ Powershift
 Forward/Reverse speeds _____ 4/3
 Maximum speed on road *** _____ 28 km/h

HYDRAULIC SYSTEM

Type _____ Load Sensing
 Hydraulic controls _____ Servo
 Simultaneous movement _____ yes
 Hydraulic pump _____ gear
 Hydraulic flow _____ 115 l/min
 Hydraulic pressure _____ 240 bar

CAPACITIES

Fuel tank _____ 135 l
 Hydraulic tank _____ 180 l

TYRES

15.5 x 22.5 _____ MICHELIN
 400/80 x 20 _____ SOLIDEAL
 400/80 x 24 _____ DUNLOP
 400/70 x 20 _____ MITAS

**EPA: Environmental Protection Agency

*** Max. speed limited according to the country's legislations

TX 130-33

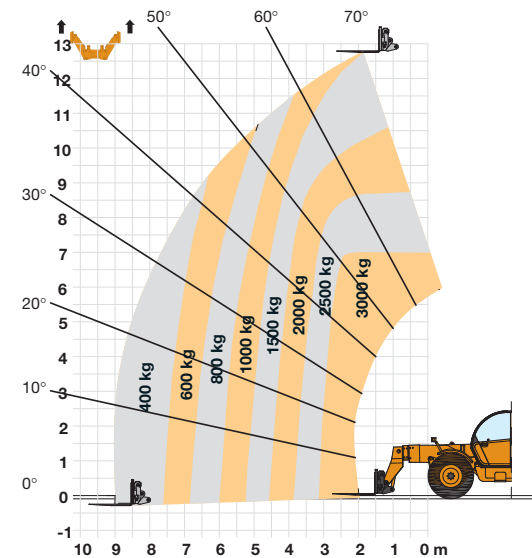
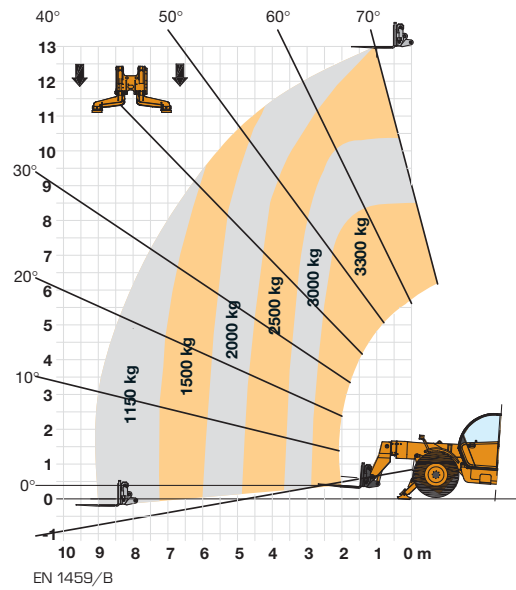

PERFORMANCE

		TX 130-33 with narrow stabilisers down	TX 130-33 with stabilisers up
Maximum lift capacity (at 500 mm from fork heel)	kg	3300	3000
Maximum lift height	m	13.0	12.7
Lift capacity at maximum reach	kg	1150	400
Lift capacity at maximum lift height	kg	2500	1500
Reach fully raised	m	1.00	2.00
Maximum forward reach	m	8.75	8.75
Height with max load	m	8.40	6.80
Breakout force	daN	7750	7750
Operating weight	kg	9900	9900

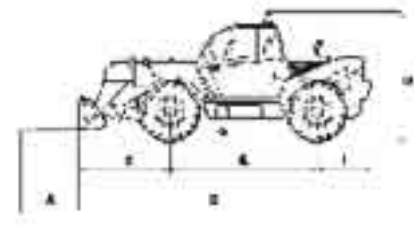
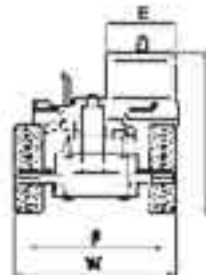
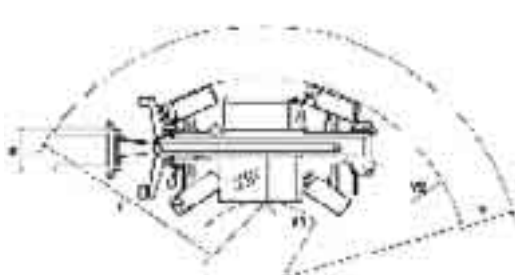

DIMENSIONS	A	B	C	D	E	F	G	H	I	K	T	U	V	V1	V2	W
With 24" rims	1200	3120	1730	5900	1000	2050	402	2450	1050	1260	4600	2730	5445	980	3890	2445
With 20" rims	1200	3120	1730	5900	1000	2040	390	2435	1050	1260	4600	2715	5445	980	3890	2445

SPECIFICATIONS

TX130-40 TX130-45

without stabilizers

with wide stabilizers

ENGINE

Make _____ CNH U.K. Limited (for Case)
 EPA ** family _____ 8NHXL04.5DAA
 Model _____ 445TA/MLE
 Engine type _____ F4GE9484J*J600
 Net Power _____ 118 hp/88 kW @2200 rpm
 _____ [According to 80/1269 CEE]
 Max Torque _____ 515 Nm@1250 rpm
 Turbo aftercooled, Tier 3, 4 cylinder, 2 valves per cylinder

TRANSMISSION

Type _____ Powershift
 Forward/Reverse speeds _____ 4/3
 Maximum speed on road *** _____ 35 km/h

HYDRAULIC SYSTEM

Type _____ Load Sensing
 Hydraulic controls _____ Servo
 Simultaneous movement _____ yes
 Hydraulic pump _____ gear
 Hydraulic flow _____ 115 l/min
 Hydraulic pressure _____ 240 bar

CAPACITIES

Fuel tank _____ 135 l
 Hydraulic tank _____ 180 l

TYRES

13.0 x 24 _____ GOOD-YEAR
 15.5 X 25 _____ MICHELIN
 405/70 x 24 _____ MITAS
 400/80 x 24 _____ DUNLOP

NOISE

Internal _____ 77 LpA
 External _____ 103 LpA

**EPA: Environmental Protection Agency

*** Max. speed limited according to the country's legislations

TX130-45

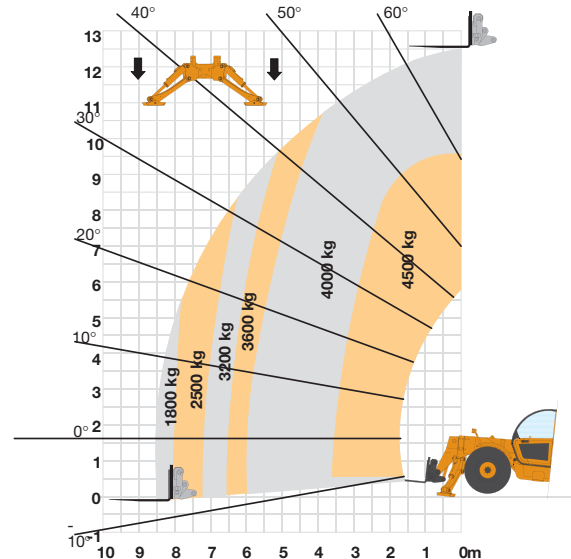

TX130-40

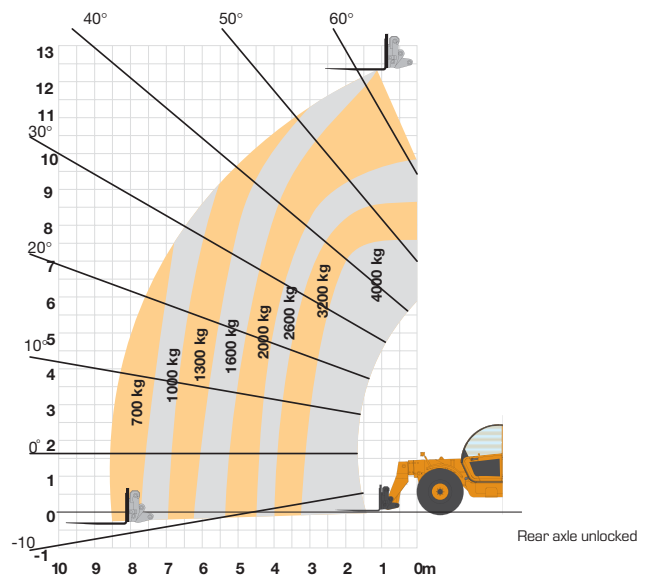

PERFORMANCE

		TX 130-40 without stabilizers	TX 130-45 with large stabilizers
Maximum lift capacity (at 500 mm from fork heel)	kg	4000	4500
Maximum lift height	m	12.30	12.45
Lift capacity at maximum reach	kg	700	1800
Lift capacity at maximum lift height	kg	2000/2600	4000
Reach fully raised	m	1.20	0.00
Maximum forward reach	m	8.65	8.65
Height with max load	m	8.50/9.50	8.20
Breakout force	daN	7750	7750
Operating weight	kg	10200	10630

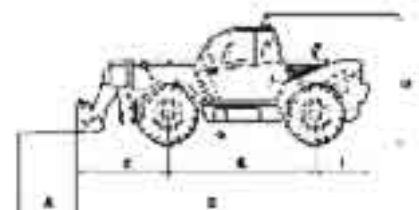
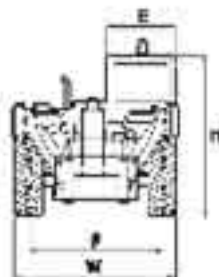
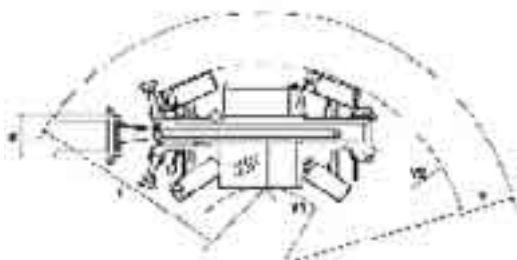

DIMENSIONS (with MITAS 405/70x24)

	A	B	C	D	E	F	G	H	I	K	T	U	V	V1	V2	W
mm	1200	3120	1617	5850	1000	2050	402	2450	1100	1260	4396	2730	5204	980	3890	2445

SPECIFICATIONS

TX140-45

with wide stabilizers

ENGINE

Make _____ CNH U.K. Limited (for Case)
 EPA** family _____ 8NHXL04.5DAA
 Model _____ 445TA/MLE
 Engine type _____ F4GE9484J*J600
 Net Power _____ 118 hp/88 kW @2200 rpm
 (According to 80/1269 CEE)
 Max Torque _____ 515 Nm@1250 rpm
 Turbo aftercooled, Tier 3, 4 cylinder, 2 valves per cylinder

TRANSMISSION

Type _____ Powershift
 Forward/Reverse speeds _____ 4/3
 Maximum speed on road*** _____ 35 km/h

HYDRAULIC SYSTEM

Type _____ Load Sensing
 Hydraulic controls _____ Servo
 Simultaneous movement _____ yes
 Hydraulic pump _____ gear
 Hydraulic flow _____ 115 l/min
 Hydraulic pressure _____ 240 bar

CAPACITIES

Fuel tank _____ 135 l
 Hydraulic tank _____ 180 l

TYRES

13.00 x 24 _____ GOOD-YEAR
 15.5 x 25 _____ MICHELIN
 405/70 x 24 _____ MITAS
 400/80 x 24 _____ DUNLOP

NOISE

Internal _____ 77 LpA
 External _____ 103 LpA

**EPA: Environmental Protection Agency

*** Max. speed limited according to the country's legislations

TX140-45

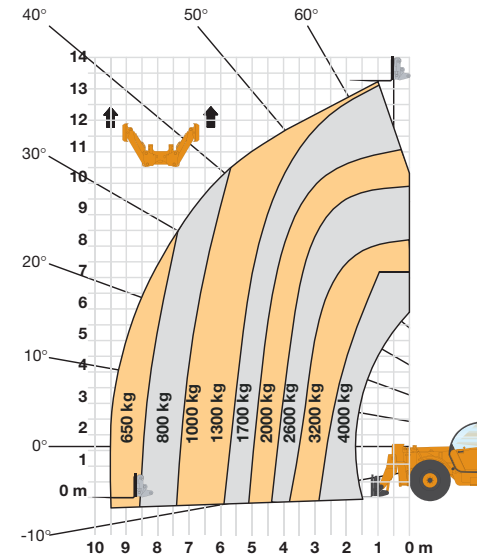
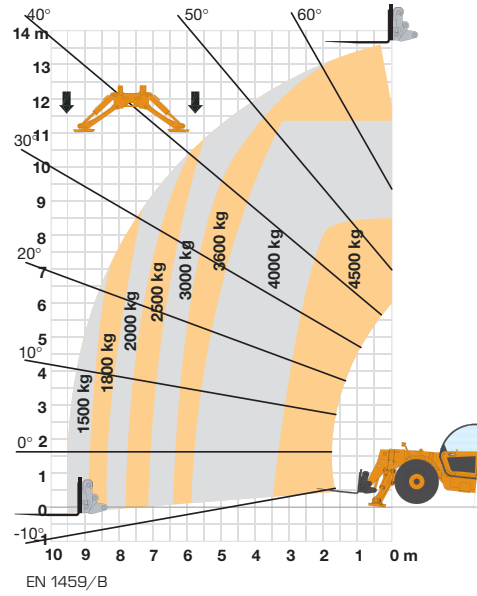

PERFORMANCE

TX 140-45 with wide stabilizers

Maximum lift capacity (at 500 mm from fork heel)	kg	4500/4000*
Maximum lift height	m	13.55/13.30*
Lift capacity at maximum reach	kg	1500/650*
Lift capacity at maximum lift height	kg	3600/1700*
Reach fully raised	m	0.30/1.00*
Maximum forward reach	m	9.33/9.33*
Height with max load	m	11.40/7.30*
Breakout force	daN	7750/7750*
Operating weight	kg	11460

* Machine with stabilizers up

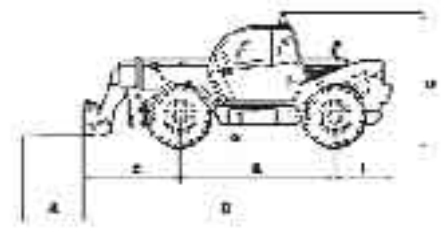
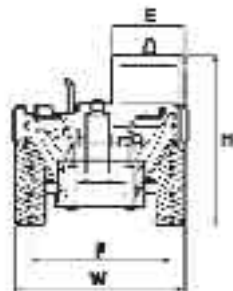
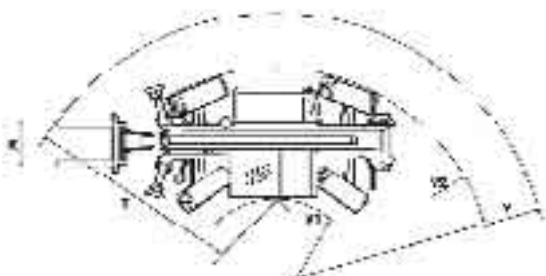

DIMENSIONS (with MITAS 405/70x24)

mm

A	B	C	D	E	F	G	H	I	K	T	U	V	V1	V2	W
1200	3120	1902	6135	1000	2050	402	2450	1100	1260	4598	2730	5445	980	3890	2445



SPECIFICATIONS

TX170-45

ENGINE

Make _____ CNH U.K. Limited (for Case)
 EPA ** family _____ 8NHXL04.5DAA
 Model _____ 445TA/MLE
 Engine type _____ F4GE9484J*J600
 Net Power _____ 118 hp/88 KW @2200 rpm
 (According to 80/1269 CEE)
 Max Torque _____ 515 Nm@1250 rpm
 Turbo aftercooled, Tier 3, 4 cylinder, 2 valves per cylinder

TRANSMISSION

Type _____ Powershift
 Forward/Reverse speeds _____ 4/3
 Maximum speed on road*** _____ 35 km/h

HYDRAULIC SYSTEM

Type _____ Load Sensing
 Hydraulic controls _____ Servo
 Simultaneous movement _____ yes
 Hydraulic pump _____ gear
 Hydraulic flow _____ 115 l/min
 Hydraulic pressure _____ 240 bar

CAPACITIES

Fuel tank _____ 135 l
 Hydraulic tank _____ 180 l

TYRES

13.00 x 24 _____ GOOD-YEAR
 15.5 X 25 _____ MICHELIN
 405/70 x 24 _____ MITAS
 400/80 x 24 _____ DUNLOP

NOISE

Internal _____ 77 LpA
 External _____ 103 LpA

** EPA: Environmental Protection Agency

*** Max. speed limited according to the country's legislations

TX170-45

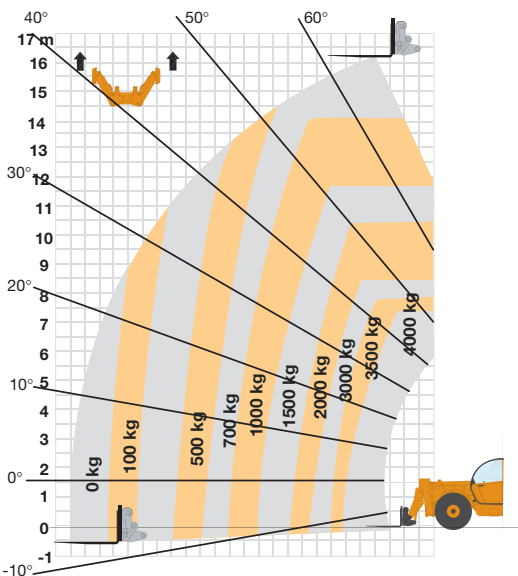
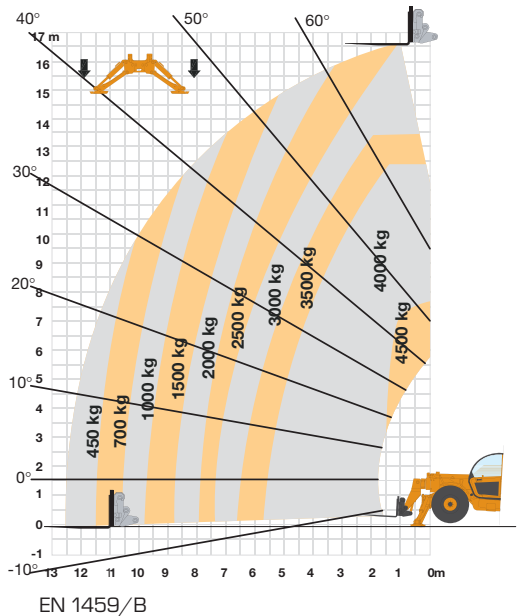

PERFORMANCE

		TX 170-45 with wide stabilizers up	TX 170-45 with wide stabilizers down
Maximum lift capacity (at 500 mm from fork heel)	kg	4000	4500
Maximum lift height	m	16.24	16.60
Lift capacity at maximum reach	kg	-	450
Lift capacity at maximum lift height	kg	700	3000
Reach fully raised	m	2.00	1.00
Maximum forward reach	m	12.54	12.54
Height with max load	m	7.40	7.95
Breakout force	daN	7750	7750
Operating weight	kg	12300	12300

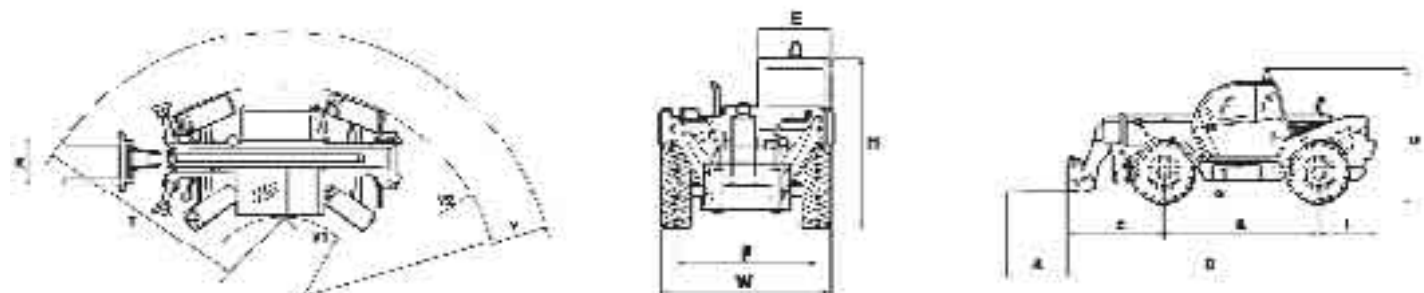

DIMENSIONS (with MITAS 405/70x24)

	A	B	C	D	E	F	G	H	I	K	T	U	V	V ₁	V ₂	W
mm	1200	3120	1902	6135	1000	2050	402	2450	1100	1260	4598	2730	5445	980	3890	2445



TX130-33/TX130-40 TX130-45/TX140-45 TX170-45

STANDARD EQUIPMENT & OPTIONS

STANDARD EQUIPMENT

Design concept

- 99hp and 188hp (both turbo aftercooled 4,5 liter 4 cylinder Tier 3)
- 4 Wheel Drive
- Powershift transmission
- 3 steering modes (2WD 4WD Crab)
- Flow sharing / Load sensing hydraulics
- Narrow (TX130) or wide (TX140/170) stabilisers
- Front axle balance control
- Independent stabilisers controls
- 2 rear lateral counterweights
- Load movement indicator and safety device
- Single battery
- Front and rear fenders
- Raincup for engine filter
- Road light support
- Road lights
- Left and right mirrors
- Mechanical parking brake
- Plate holder

Boom

- Chain (TX130 - 33) or Cylinder (others) boom extension
- 3 piece (TX130 / 140) or 4 piece (TX170) boom
- Self levelling
- Single lever hydraulic pilot control

Cab comfort

- Cloth seat with seat belt
- Rounded windshield with wiper
- Split door opening at 180°
- Sun visor
- Heating and efficient defrosting
- Single lever joystick (extension, boom, bucket, transmission cutout, hydraulic circuit)

Safety

- ROPS/FOPS cab
- Load movement indicator
- Hazardous boom extension warning (TX130-33) or stopping (other TX's) device
- Sun roof protection grill
- Seat belt
- Safety decals

- Noise insulation meeting european standards
- Safety valves on lift - tilting - boom - stabilizers
- Backup alarm

OPTIONS

Choice of tyres (construction or agricultural pattern)

Choice of tyre sizes

Boom

- Hydraulic connection for attachment
- Boom working lights
- Electric circuit side boom

Tools

- Choice of Case/CNH or competition carriers (mechanical or Hydraulic)
- Choice of fixed or sideshift carriage
- Choice of buckets (Std, 4x1) with blade or teeth
- Choice of forks (fixed or floating)
- Fork extension
- Hooks
- Truss boom
- Extendible crane jib
- Concrete mixer
- Basket material handling
- Other
- Manplatform with or without Remote control

Cab

- Air conditioning
- Cloth deluxe suspension seat with seat belt
- Rear wiper
- Roof wiper
- Steering wheel knob
- External screen guard
- 2 front working lights
- 1 rear working light
- Titable steering wheel
- Other
- Twin batteries
- Cold start engine
- Limited slip differential on front axle
- Rotating beacon
- Trailer hook

Standard and optional equipment shown can vary by country.

Worldwide Case Construction Equipment Contact Information

EUROPE/AFRICA/MIDDLE EAST:
Centre D'affaires EGB
5, Avenue Georges Bataille - BP 40401
60671 Le Plessis-Belleville - FRANCE

NORTH AMERICA/MEXICO:
700 State Street
Racine, WI 53404 U.S.A.

LATIN AMERICA:
Av. General David Sarnoff 2237
32210 - 900 Contagem - MG
Belo Horizonte BRAZIL

ASIA PACIFIC:
Unit 1 - 1 Foundation Place - Prospect
New South Wales - 2148 AUSTRALIA

CHINA:
No. 29, Industrial Premises, No. 376,
De Bao Road, Waigaoqiao Ftz, Pudong,
SHANGHAI, 200131, P.R.C.



The call is free from a land line. Check in advance with your Mobile Operator if you will be charged.

NOTE: Standard and optional fittings can vary according to the demands and specific regulations of each country. The illustrations may include optional rather than standard fittings - consult your Case dealer. Furthermore, CNH reserves the right to modify machine specifications without incurring any obligation relating to such changes.



Conforms to directive 98/37/CE

CASE Construction Equipment

CNH UK Ltd
Unit 4,
Hayfield Lane Business Park,
Field Lane, Auckley,
Doncaster,
DN9 3FL
Tel. 00800-2273-7373
Fax +44 1302 802829

www.casece.com

CASE
CONSTRUCTION